

Understanding the UNFCCC Process: Legal and Procedural Issues and Negotiation Management

30 June 2026



Moderator

Mr. Andrea Camponogara

RCC Global Lead

Mitigation division, UNFCCC



United Nations
Climate Change

Housekeeping

- Please mute your microphone.
- Please introduce yourself in the chat by sharing your name and the Party/Institution you represent.
- Please submit questions using the chat function. When submitting questions, please indicate your name and the Party/Institution you represent.



Ms. Cecilia Kinuthia-Njenga
Director
Intergovernmental Support and
Collective Progress division, UNFCCC



United Nations
Climate Change

Mr. Gianluca Crispi
Legal Officer
Legal Affairs division, UNFCCC



United Nations
Climate Change



Introduction to the UNFCCC process and its institutions



United Nations
Climate Change

International Climate Change Regime



The UNFCCC

- General commitments All Parties to report GHG inventories (Article 4.1(a) and 12.1) and national communications (Article 12.5)
- Specific commitments on Annex I Parties: mitigation commitments (Article 4.2(a) and (b) and 12.2(a)) and on Annex II Parties: financial assistance and technology transfer commitments (Articles 4.3 and 4.4)

The Kyoto Protocol

- It sets specific legally-binding emission reduction targets for Annex I Parties. 2 commitments periods 2008-2012 and 2013-2020

The Paris Agreement

- Based on a bottom-up approach in which all Parties decide on their own commitments, communicated through their Nationally Determined Contributions. No annexes but developed and developing country Parties



Institutional Structure of the UNFCCC Intergovernmental Process

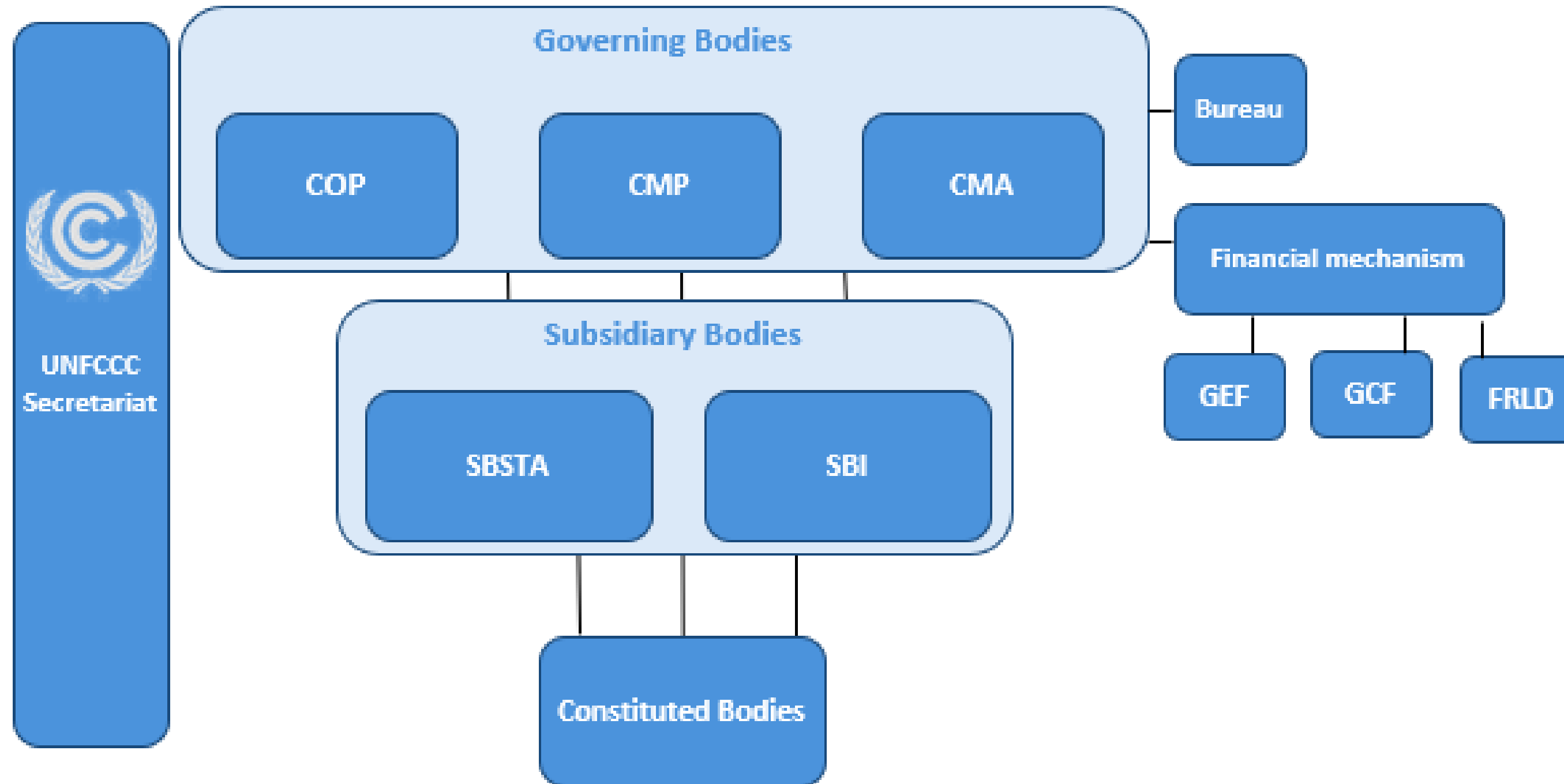

Constituted bodies under the UNFCCC process

Adaptation Committee	Least Developed Countries Expert Group
Technology ExCom (TEC)	CTCN Advisory Board
Adaptation fund Board	Facilitative Working Group of the LCIPP
A. 6.4 Supervisory Body	Standing Committee on Finance
WIM Ex Comm	Santiago network Advisory Board
Kyoto Protocol Compliance Committee	Paris Agreement Implementation and Compliance Committee
Consultative Group of Experts	Paris Committee on Capacity-building
CDM Executive Board	Katowice Committee of Experts



United Nations
Climate Change



Main thematic streams

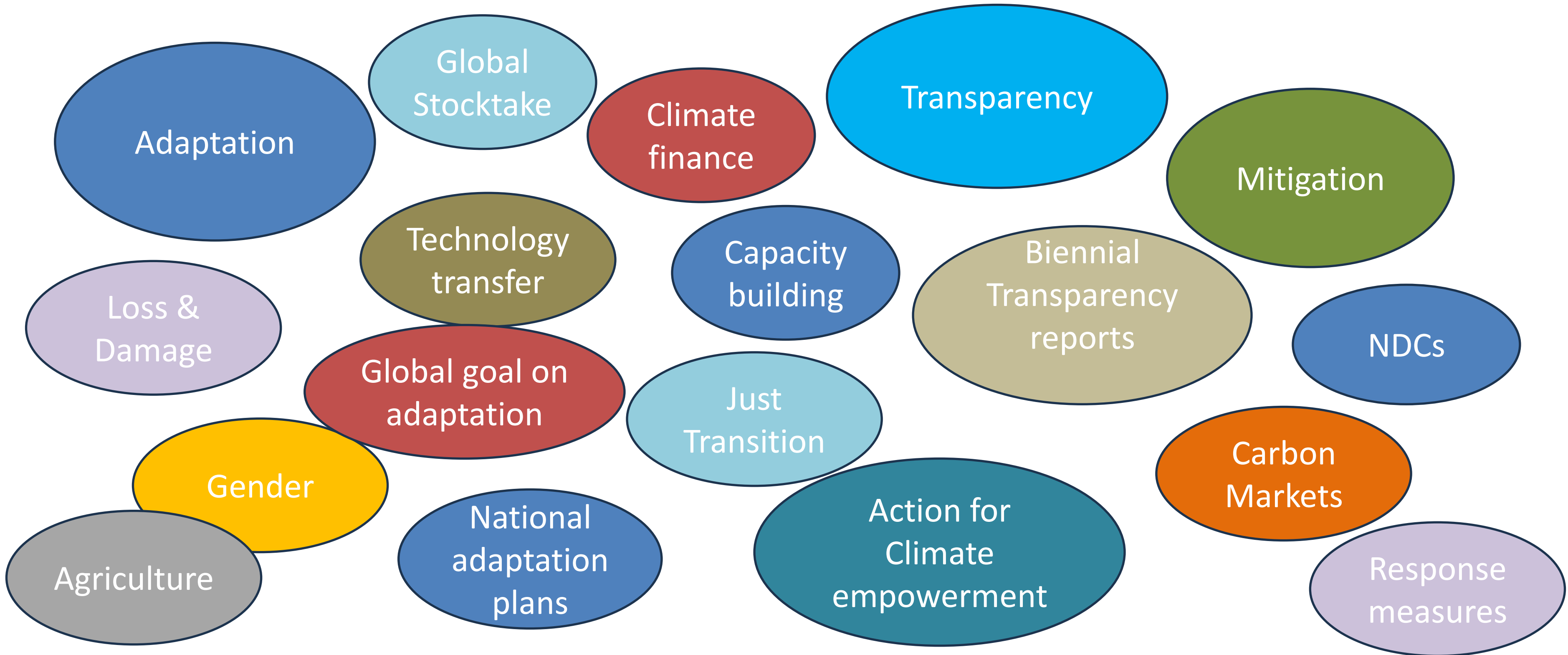

Overview of the draft rules of procedure



United Nations
Climate Change

Draft rules of procedure

- Draft rules of procedure are the **rules of the game**
 - Provide for equal treatment of all Parties
 - Ensure certainty, predictability and orderly conduct of proceedings
 - Define rights and responsibilities of Presiding Officers, Parties and the secretariat, and participation of observers
- Art. 7.3 UNFCCC: COP to adopt its rules of procedure at its first session
 - The draft rules of procedure were presented to COP 1 for adoption, but there were disagreements over draft rule 42 (voting)
- **Not yet adopted**
 - No consensus on rule 42 (voting) – all other draft rules apply though
 - At each session, the COP agrees to apply the draft rules of procedure with the exception of draft rule 42



Consensus decision-making

- Decision-making is done by **consensus** in the UNFCCC process
 - “Consensus” is not formally defined
 - In UN practice, it's the adoption of decisions:
 - By general agreement;
 - Without resort to voting; and
 - Absent any formal objection
- Consensus **does not mean every Party must favor every element of the decision**
 - A Party can still make reservations, declarations, or statements of interpretation/position
- These don't necessarily mean a Party intends to block consensus
 - **In case of uncertainty, Presiding Officers must check**



Draft rules of procedure

What do the draft rules of procedure cover? For example...

- Preparation of the provisional agenda (rules 9-11)
- Quorum for meetings (rule 31)
- Officers of the Bureau of the COP (e.g. rule 22)
- Functions and powers of the President (e.g. rule 23)
- Points of order (e.g. rule 34)
- Procedural motions (e.g. rule 35)
- Credentials (rules 17-21)
- Application of the draft rules of procedure to the SBs (rule 27)
- Observers (rules 6-8)
- Languages and interpretation (e.g. rules 54-56)
- ...and other draft rules





How decisions are adopted



How are decisions adopted

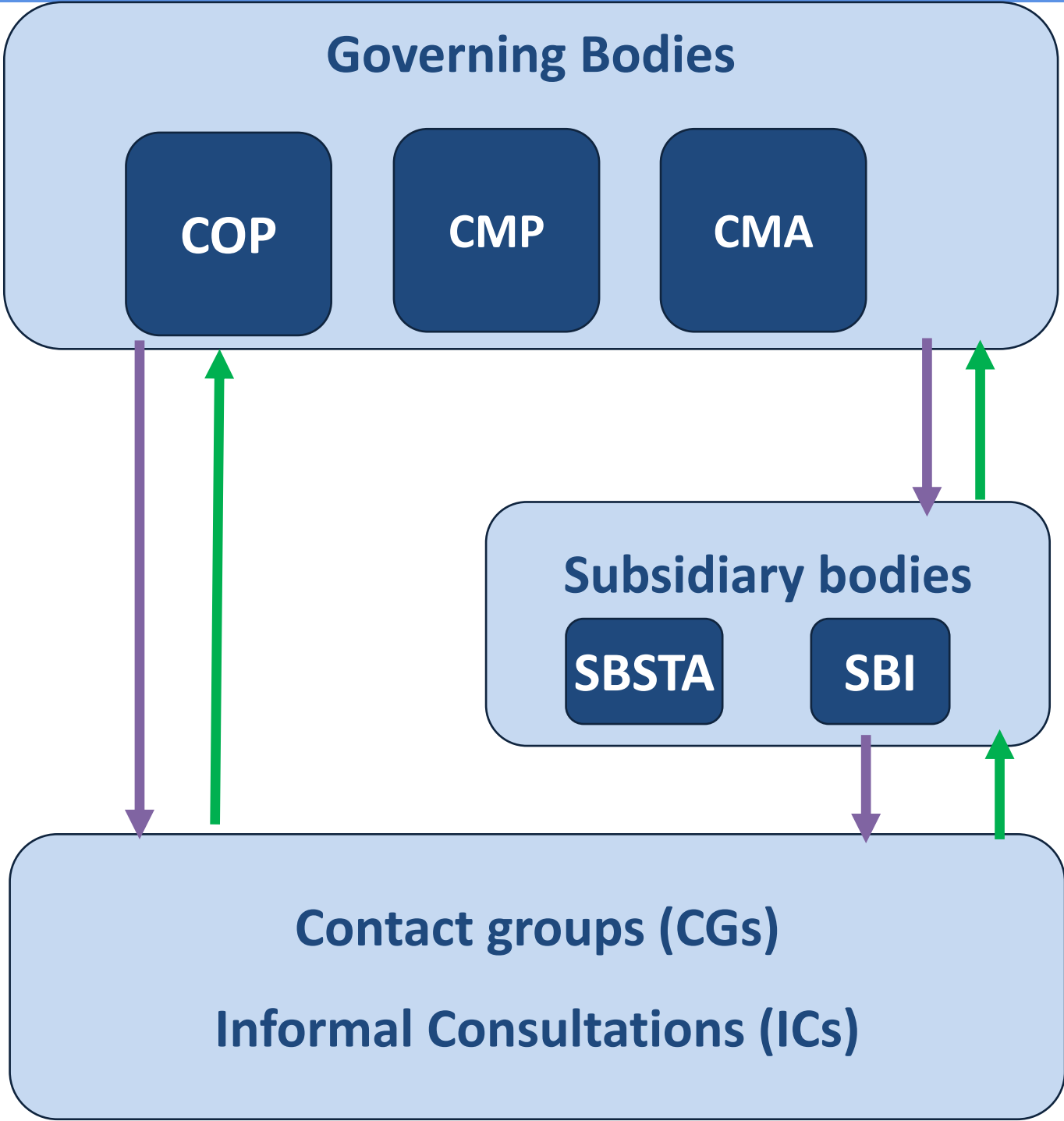

Decision adopted



United Nations

FCCC/CP/2025/L.13



Framework Convention on Climate Change

Distr.: Limited
22 November 2025

Original: English

Conference of the Parties

Thirtieth session
Belém, 10–21 November 2025
Agenda item 2(g)

Organizational matters
Dates and venues of future sessions

Organizational matters

Proposal by the President

Draft decision -/CP.30

Dates and venues of future sessions

The Conference of the Parties,
Recalling Article 7, paragraph 4, of the Convention,
Also recalling United Nations General Assembly resolution 40/243 of 18 December 1985 on the pattern of conferences,
Further recalling rule 22, paragraph 1, of the draft rules of procedure being applied regarding the rotation of the office of President among the five United Nations regional groups,

Ministerial informal

Friends of the Chair

Informal-informal



United Nations
Climate Change



Developing draft texts: CFs' draft informal notes ► draft decisions and conclusions

1. CFs mandated to prepare drafts **as soon as possible**
2. CFs with secretariat support prepare **an informal note** capturing views shared in the negotiating room
3. Draft text is shared by email with Parties & posted on GB/SB session website ahead of next negotiation meeting
4. Parties meet to discuss and share their views
5. CFs with secretariat prepares next iteration capturing any views shared in the room
6. For efficiency, **no drafting on screen**
7. Final meeting of negotiating group – draft text agreed
8. After final meeting, secretariat prepares draft decision/conclusions for adoption at closing plenary

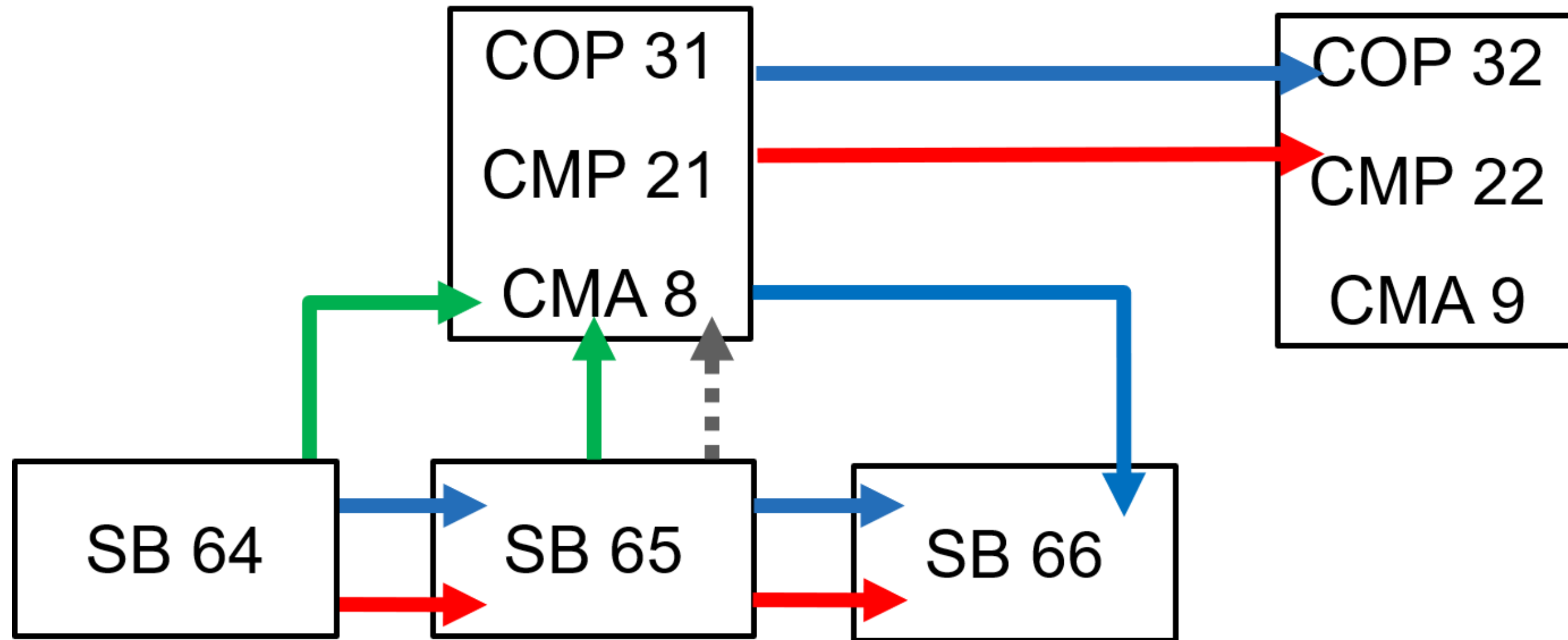

Possible outcomes and rule 16



-  SBs recommend to the GBs completed work
-  Body agrees to continue work at a future session on the basis of some text
-  Rule 16



Ms. Nattley Williams

Manager

**Intergovernmental Support and Collective Progress
division, UNFCCC**



United Nations
Climate Change



Negotiations Management



United Nations
Climate Change

Participants at COP 20 – COP 30

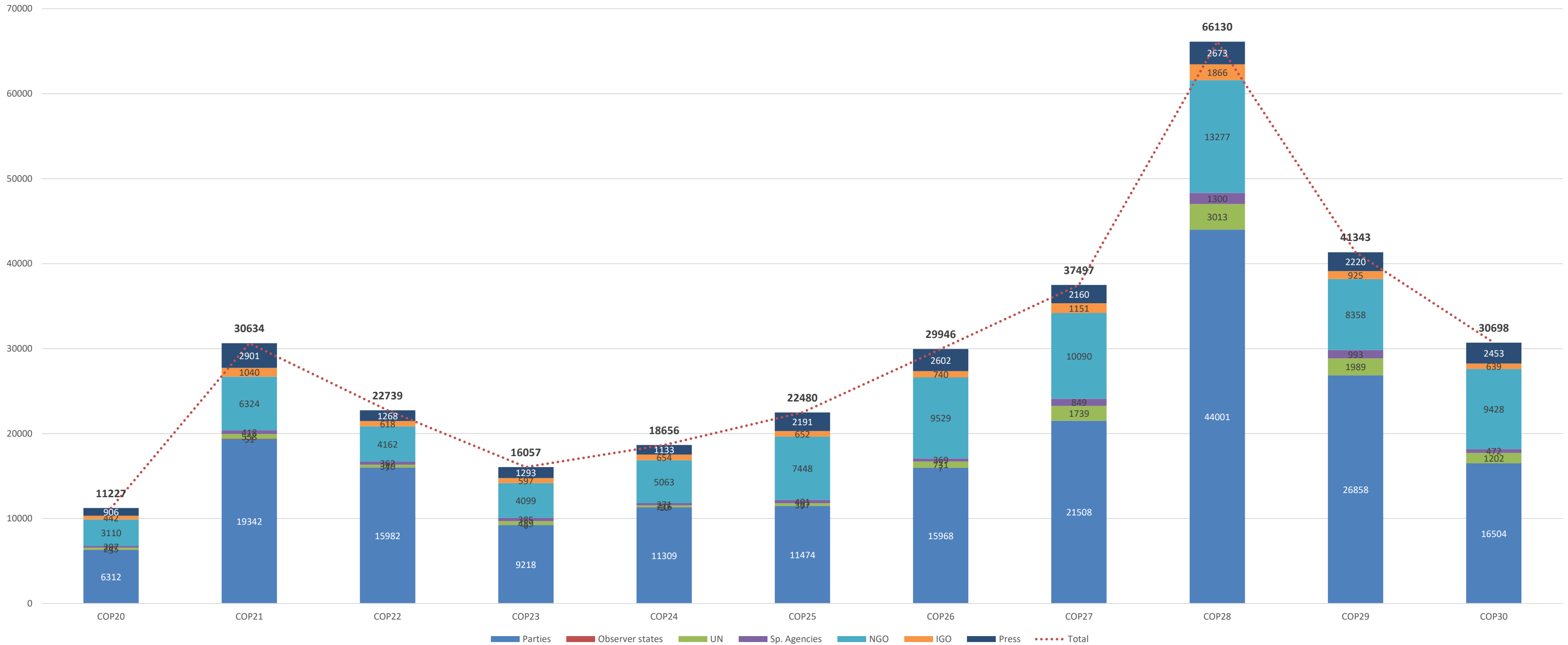

Overview of COP 30

COP 30 Pre-sessionals: 04-09 November 2025 COP 30: 10-21 November 2025



04-09 Nov	Week 1: 10-15 Nov			Week 2: 17-21 Nov	
<p>Leaders Summit 6-7 Nov</p> <p>Negotiating groups coordination meetings 4-9 Nov</p> <p>Presidency shuttle diplomacy with groups</p> <p>SB Chairs shuttle diplomacy with groups</p> <p>Bureau meeting 8 Nov</p> <p>HoDs on agendas adoption 9 Nov</p>	<p>COP/ CMP/ CMA Opening</p> <p>&</p> <p>SBs Opening</p> <p>10 Nov</p>	<p>Presidency and SB Chairs shuttle diplomacy</p> <p>Governing/subsidiary bodies negotiations</p> <p>Bureau meeting</p> <p>Mandated, Presidency, Global Climate Action events</p> <p>Negotiating groups coordination meetings</p>	<p>SBs Closing</p> <p>&</p> <p>GB plenaries adopt decisions /week 2 end-game</p> <p>15 Nov</p>	<p>Presidency shuttle diplomacy</p> <p>High-level Segment 17-19 Nov</p> <p>Governing body negotiations and Ministerial engagement</p> <p>Bureau meeting</p> <p>Presidency informal stock take plenaries</p> <p>Mandated, Presidency, Global Climate Action events</p>	<p>COP/ CMP/ CMA Closing 21 Nov</p>



Types of meetings

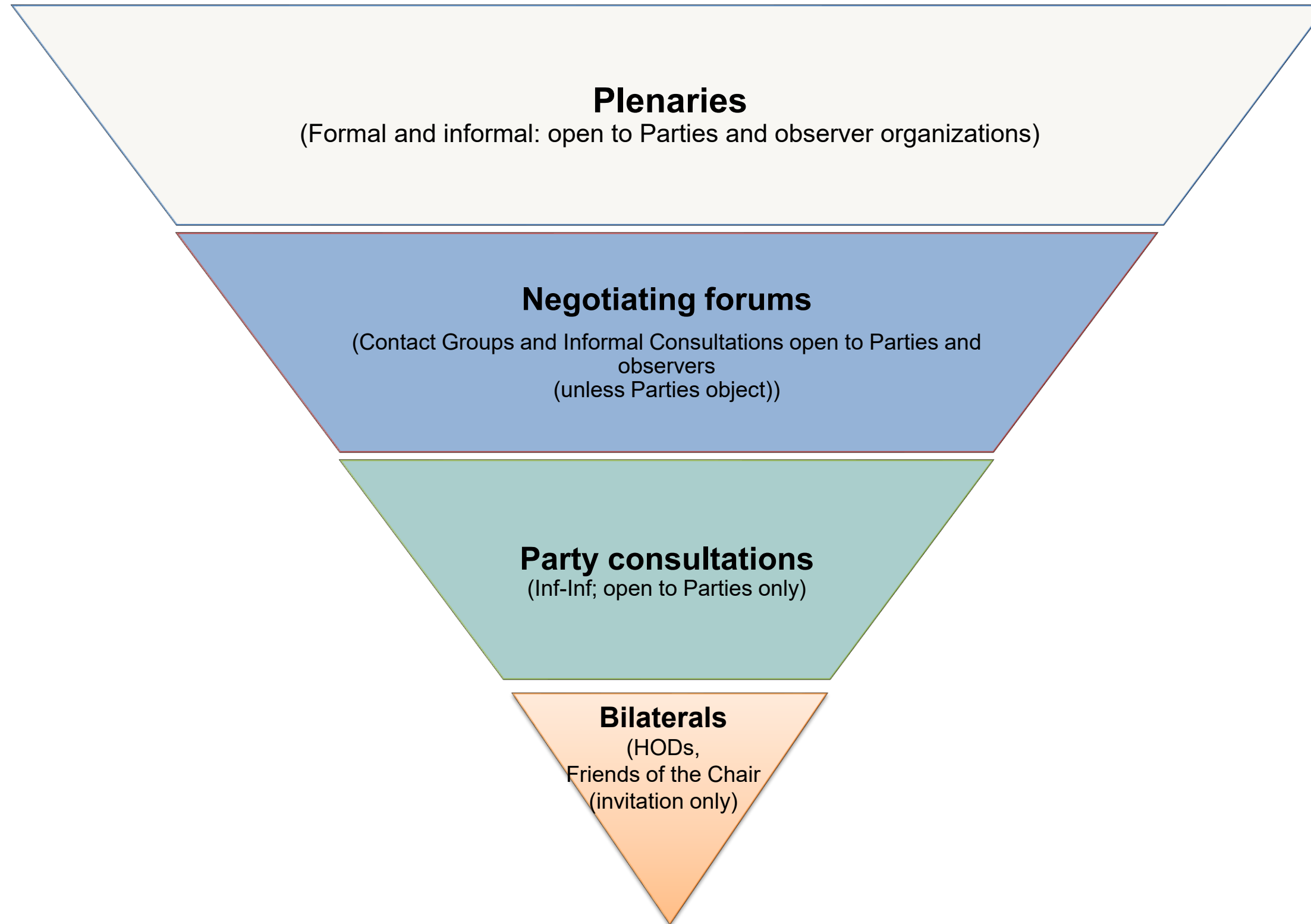

Organizing work

- Opening and closing plenaries convened together
- Swift adoption of agendas
- Immediate launch of work
- Strict enforcement of speaking limit for statements — bell, clock, turn off mic
- Statements posted on session webpage
- Virtual participation for registered participants
- Time management - negotiations from 10:00 -13:00 hours and 15:00 - 18:00 hours, extended hours on final days
- Mandated and Presidency events during lunch time (13:00 – 15:00)
- Communication tools for transparency and inclusivity (website, virtual platform, ITV, Official notifications, informal “Stocktake” plenaries, letters from the President)
- Draft decisions gaveled the last day of the governing / subsidiary bodies sessions, reports issued later
- To reach agreement: Presidency shuttle diplomacy / Heads of Delegation meetings



Party Groupings in the UNFCCC

G77 and China (135 Parties)	African Group (54 Parties)	Bolivarian Alliance for the Peoples of Our America (ALBA) (5 Parties)	Like-minded Developing Countries (LMDC) (25 Parties)
European Union (27 Parties)	Independent Association of Latin America and the Caribbean (AILAC) (8 Parties)	BASIC (4 Parties)	Mountain Group (10 Parties)
Umbrella Group (11 Parties)	Least Developed Countries (44 Parties)	Grupo SUR (5 Parties)	Coalition for Rainforest Nations (CfRN) (53 Parties)
Environmental Integrity Group (6 Parties)	Arab Group of States (22 Parties)	Group of Landlocked Developing Countries (LLDCs) (32 Parties)	AOSIS (Alliance of Small Island States (AOSIS) (39 Parties)



UNFCCC Observers Constituency

BINGO	Business and industry NGOs
ENGO	Environmental NGOs
Farmers	Farmers and agricultural NGOs
IPO	Indigenous Peoples organizations
LGMA	Local government and municipal authorities
RINGO	Research and independent NGOs
TUNGO	Trade union NGOs
WGC	Women and gender constituency
YOUNGO	Children and youth NGOs



Code of Conduct

- Promote **respectful behavior** for a safe, productive environment
- Prevent interruptions and shouting
- **Ensure all voices are heard** and invite others to speak
- **Intervene immediately** if boundaries are crossed
- **Report** any behavior that goes against the Code of Conduct

➤ SpeakUp@unfccc.int

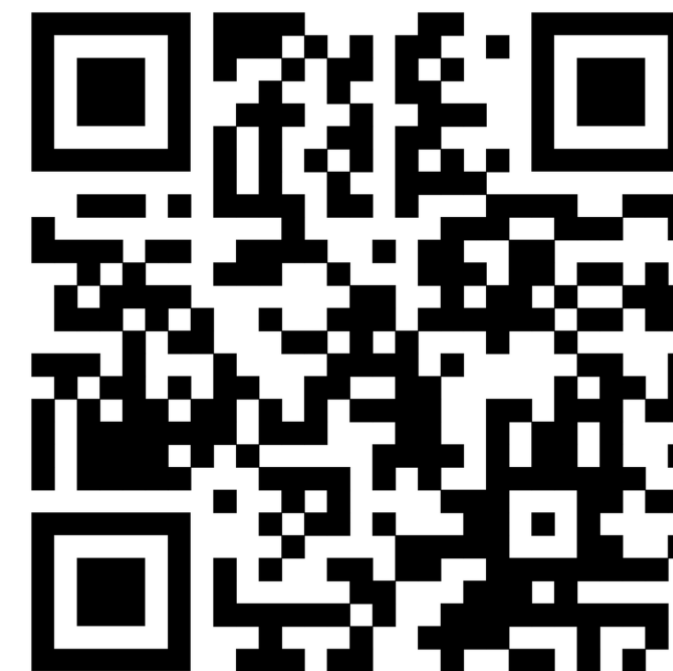
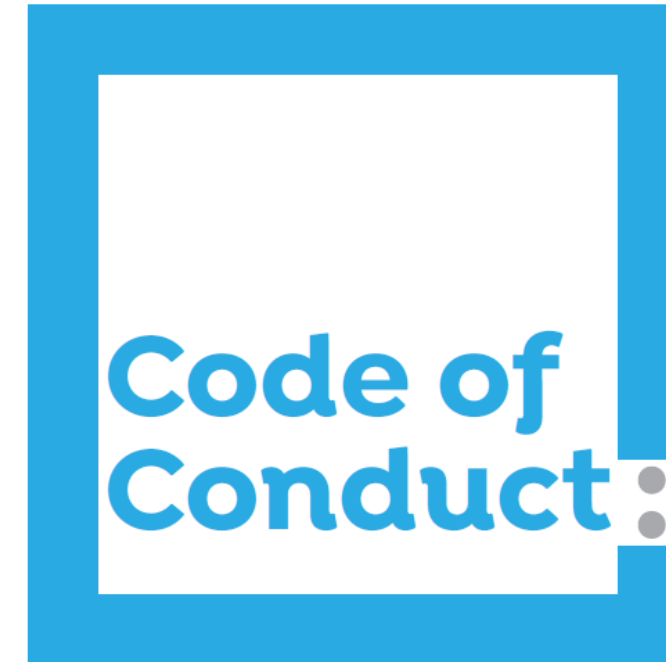

Presiding Officers' Guide



Presiding Officers' Guide

to the UNFCCC Process



United Nations
Climate Change

Moderator for Q&A

Ms. Ulfath Ibrahim

**Intergovernmental Support and Collective
Progress division, UNFCCC**



United Nations
Climate Change

Thank you!



United Nations
Climate Change